

PLANNING DEPARTMENT USE ONLY (E-PLANS)

LEGEND

- FIRE ACCESS LANE
Meets apparatus loading to be no less than 85,000 lbs or meet tertiary road subgrade.
- EXISTING / PROPOSED FIRE HYDRANT
- PRIMARY BUILDING ACCESS WITHIN 50'

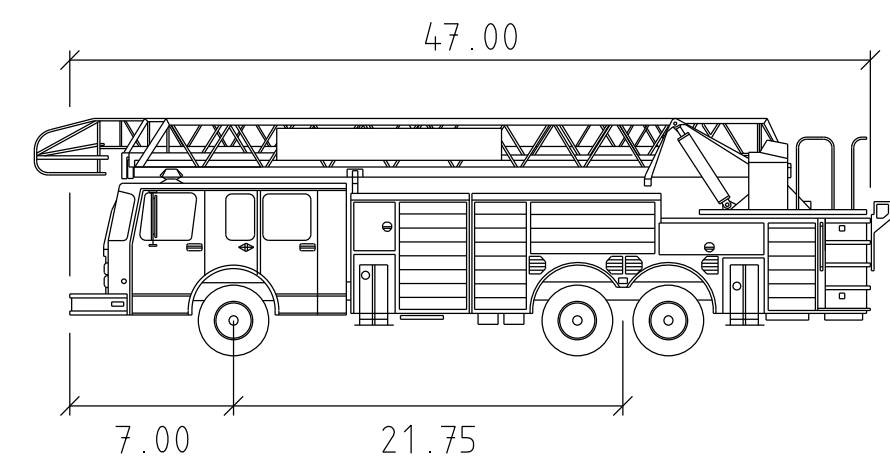

AT-29 GERMANTOWN feet

- Width : 8.25
- Track : 8.25
- Lock to Lock Time : 6.00
- Steering Angle : 33.20

EAST JEFFERSON STREET
(VARIABLE WIDTH RW)

MONTROSE ROAD
(VARIABLE WIDTH RW)

MATCHLINE - SHEET 3



STONEHENGE PLACE
(PUBLIC)

PRIVATE STREET 'B'

MONTROSE PARKWAY
(130' RW)

ENGINEER'S CERTIFICATE

I HEREBY CERTIFY, TO THE BEST OF MY PROFESSIONAL KNOWLEDGE, INFORMATION AND BELIEF, THAT THE PLAN SHOWS HEREON CONFORMS WITH THE MONTGOMERY COUNTY SUBDIVISION REGULATIONS AS ADOPTED OCTOBER 1961 AND AS AMENDED THEREAFTER.

SIGNATURE: BRANDON J. FRITZ, P.E. TITLE: PROJECT MANAGER
DATE: _____
PRINTED NAME: BRANDON J. FRITZ, P.E. TITLE: PROJECT MANAGER
MD. REG. NO. 26286

PROFESSIONAL CERTIFICATION

I HEREBY CERTIFY THAT THESE DOCUMENTS WERE PREPARED OR APPROVED BY ME, AND THAT I AM A DULY LICENSED PROFESSIONAL ENGINEER UNDER THE LAWS OF THE STATE OF MARYLAND.
LICENSE NO. 26286 EXPIRATION DATE: 06/21/21



FIRE DEPARTMENT ACCESS PLAN

PRELIMINARY PLAN
WILGUS TRACT
120200140

POTOMAC (1ST) ELECTION DISTRICT, MONTGOMERY COUNTY, MARYLAND

SOLTESZ, INC.
Rockville
Lanham
Waldorf
Leonardtown
Frederick
Soltesz DC, LLC

ROCKVILLE OFFICE
2 Research Place, Suite 100
Rockville, MD 20850
P. 301.948.2750 F. 301.948.9067

www.soltesz.com

NO.	DATE	REVISIONS	BY	DATE
1	JANUARY 2020	CAO STANDARDS VERSION: V8 - NCS		
	DESIGNED: KDL	TECHNICIAN: NC	CHECKED: BJF	

MISS UTILITY NOTE

INFORMATION CONCERNING EXISTING UNDERGROUND UTILITIES WAS OBTAINED FROM AVAILABLE RECORDS. THE CONTRACTOR MUST DETERMINE THE EXACT LOCATION AND ELEVATION OF ALL EXISTING UTILITIES AND UTILITY CROSSINGS BY EXCAVATING TEST PITS BY HAND, WELL IN ADVANCE OF THE START OF EXCAVATION. CONTACT "MISS UTILITY" AT 1-800-261-7777, 48 HOURS PRIOR TO THE START OF EXCAVATION. IF CLEARANCES ARE LESS THAN SHOWN ON THE PLAN OR TWELVE (12) INCHES, WHICHEVER IS LESS, CONTACT THE ENGINEER AND THE UTILITY COMPANY BEFORE PROCEEDING WITH CONSTRUCTION. CLEARANCES LESS THAN NOTED MAY REQUIRE REVISIONS TO THIS PLAN.

OWNER/DEVELOPER/APPLICANT

WILGUS/MONTROSE ASSOCIATES LLC
7811 MONTROSE ROAD
SUITE 200
POTOMAC, MD 20854
PHONE: (301) 396-1500
ROCKEN@WILLCO.COM
RICHARD COHEN

MAP: ADC	GRID: 5285
TAX MAP: Q062	DRAWING CATEGORY: CIVIL - CIVIL - 06 - 0600
WBCS 200 SHEET: 215 NW 06	CRS: 2011, 2012, 2013, 2014, 2015, 2016, 2017, 2018, 2019, 2020, 2021
SITE DATUM: HORIZONTAL: NAD83	
VERTICAL: NAD83	

1" = 40'	
SHEET	2
OF	3
PROJECT NO.	120200140
DATE	12/26/20