

- SURVEY NOTES:
1. HORIZONTAL DATUM :NAD 83 - MARYLAND STATE PLANE
 2. VERTICAL DATUM - NAVD 88
 3. CONTOUR INTERVAL IS 2 FOOT
 4. THIS SURVEY WAS PERFORMED BY LIGGIE SURVEYS, INC.
 5. UNDERGROUND UTILITY MARKINGS PERFORMED BY MISS UTILITY

PROFESSIONAL CERTIFICATION

I HEREBY CERTIFY THAT THESE DOCUMENTS
 WERE PREPARED OR APPROVED BY ME, AND
 THAT I AM A DULY LICENSED PROFESSIONAL
 ENGINEER UNDER THE LAWS OF THE STATE OF
 MARYLAND, LICENSED NO. 23093, EXPIRATION
 DATE 05/06/2025

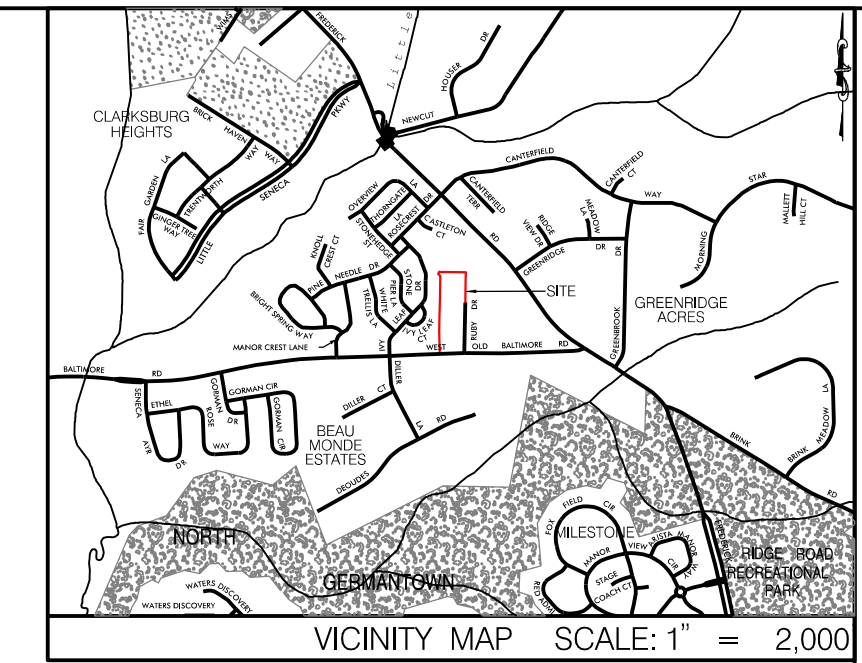

ENDESCO, INC.
 ENGINEERS, DESIGNERS &
 CONSULTANTS

16245 SHADY GROVE RD
 SUITE 335
 ROCKVILLE, MD 20850
 TEL: (301) 987-8776
 FAX: (301) 987-8777

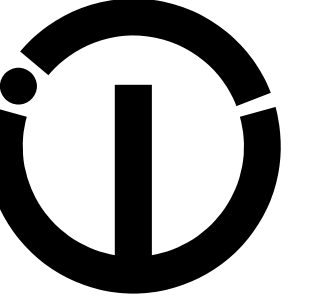

PT LOT 1, LOTS 2 AND 3
 RUBY SENIOR HOMES
 MONTGOMERY COUNTY, MARYLAND

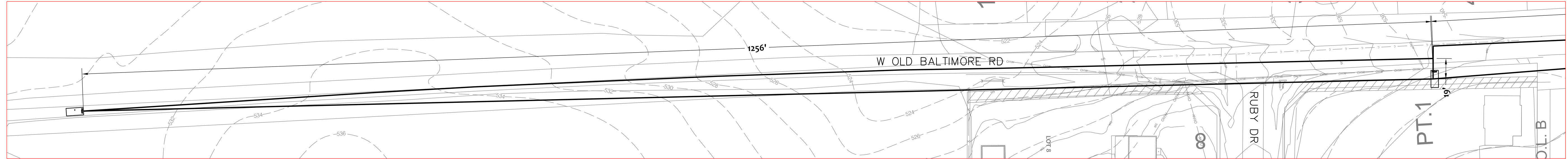

PLAN VIEW 1
 SCALE: 1"=50'

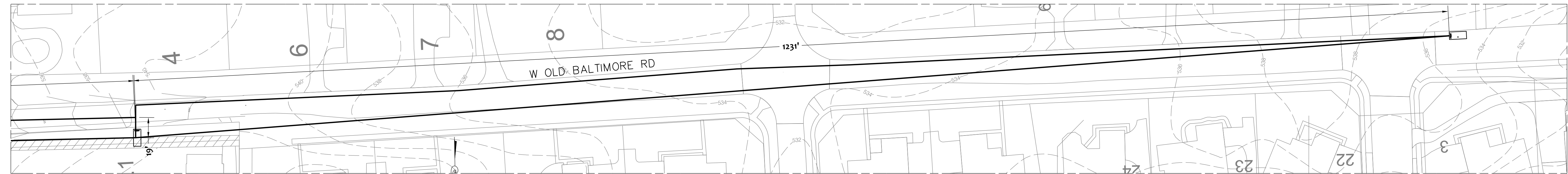

PLAN VIEW 2
 SCALE: 1"=50'

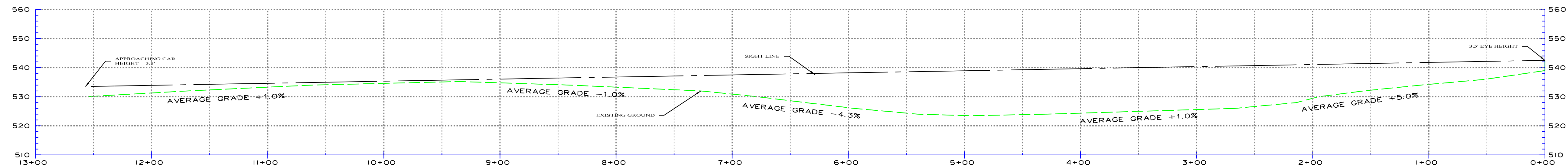

RIGHT TURN - LOOKING LEFT
 SCALE HORIZONTAL: 1"=50'
 SCALE VERTICAL: 1"=20'

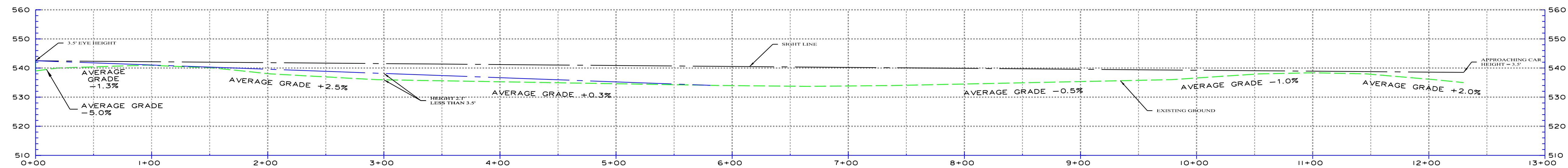

RIGHT TURN - LOOKING RIGHT
 SCALE HORIZONTAL: 1"=50'
 SCALE VERTICAL: 1"=20'

REVISIONS

NO.	DATE	DESCRIPTION
1.		
2.		
3.		
4.		

TITLE
 SIGHT DISTANCE PLAN

DATE
 JUN 2024

SCALE
 N.T.S.

SHEET
 CPP-1

DRAWN:
 GJ

DESIGNED:
 GJ

CHECKED:
 KH