

**VKA**  
 ENGINEERS PLANNERS  
 LANDSCAPE ARCHITECTS SURVEYORS  
 VIKI MARYLAND, LLC  
 20251 CENTURY BOULEVARD, SUITE 400  
 GERMANTOWN, MARYLAND 20874  
 PHONE: (301) 916-4100  
 FAX: (301) 916-2262  
 GERMANTOWN, MD. MCLEAN, VA.

PREPARED FOR:  
**USL2 MR MONTGOMERY VILLAGE BUSINESS TRUST**  
 c/o MONUMENT REALTY  
 1700 K STREET, NW, SUITE 600  
 WASHINGTON, DC 20006  
 202.777.2010  
 RUSSELL HINES

DESIGN CONSULTANTS  
**ARCHITECTS**  
 TORTI GALLAS AND PARTNERS, INC.  
 1300 SPRING STREET, SUITE 400  
 SILVER SPRING, MD 20910  
 301.588.4800  
 ERIK J. AULESTIA

ATTORNEY  
**LERCH, EARLY & BREWER**  
 CHTD.  
 3 BETHESDA METRO CENTER  
 SUITE 460  
 BETHESDA, MD 20814  
 301.841.3832  
 PATRICIA HARRIS

TRAFFIC ENGINEER  
**WELLS + ASSOCIATES**  
 8730 GEORGIA AVENUE, SUITE 200  
 WASHINGTON, DC 20910  
 301.448.1333  
 KEVIN BERGER

LANDSCAPE ARCHITECT  
**VIKA MARYLAND, LLC**  
 20251 CENTURY BOULEVARD  
 SUITE 400  
 GERMANTOWN MD, 20874  
 301.916.4100  
 JOSH SLOAN

CIVIL ENGINEER  
**VIKA MARYLAND, LLC**  
 20251 CENTURY BOULEVARD  
 SUITE 400  
 GERMANTOWN MD, 20874  
 301.916.4100  
 MIKE GOODMAN

REVISIONS	DATE
1ST SUBMISSION	05/05/17
DRC COMMENTS	08/09/17
REVIEWER COMMENTS	08/31/17



I HEREBY CERTIFY THAT THESE DOCUMENTS WERE PREPARED OR APPROVED BY ME, AND THAT I AM A DULY LICENSED REGISTERED LANDSCAPE ARCHITECT UNDER THE LAWS OF THE STATE OF MARYLAND.  
 NAME: JOSHUA SLOAN, No. 3776  
 EXPIRATION DATE: MAY 13, 2019

**BLOOM MV AREA I-VI**  
 9TH ELECTION DISTRICT  
 MONTGOMERY COUNTY, MARYLAND  
 WSSC GRID: 227NW09  
 TAX MAP: FU342  
**820170130**

**FINAL FOREST CONSERVATION PLAN**  
**AREA 5 DETAILED FCP**

DRAWN BY:          NRP  
 DESIGNED BY:          JCS  
 DATE ISSUED:          AUGUST, 2017  
 VIKI PROJECT:          VM1920  
 DRAWING NO.:           
 SHEET NO.:          FFCP-351

**LEGEND**

	SUBJECT PROPERTY		EXISTING SPECIMEN TREE 30" OR GREATER DBH W/CRZ SHOWN
	ADJACENT PROPERTY/LOT LINES		EXISTING SPECIMEN TREE 24-29 1/2" TO BE REMOVED
	LIMITS OF DISTURBANCE		EXISTING SPECIMEN TREE 30" OR GREATER TO BE REMOVED
	100 YEAR FLOODPLAIN		EXISTING SPECIMEN TREE 100' IMPACT SHOWN
	25' BRL STREAM VALLEY BUFFER		EXISTING SPECIMEN TREE WITH 100% IMPACT NOT HATCHED
	WETLAND BUFFER		EXISTING SIGNIFICANT TREE 14-29 1/2" DBH W/CRZ SHOWN
	WATERS OF THE US		PROPOSED CATEGORY I FOREST CONSERVATION EASEMENT
	PROPOSED FOREST CONSERVATION EASEMENT		PROPOSED CATEGORY II FOREST CONSERVATION EASEMENT
	SOILS		PROPOSED AFFORESTATION/REFORESTATION
	EX. FORESTED UTILITY EASEMENT		PROPOSED BIORETENTION
	ROOT PRUNING TRENCH AT CONSTRUCTION TREE		EXISTING TREE CANOPY (NOT FOREST)
	PROTECTION FENCE W/ SIGNAGE		EXISTING SIGNIFICANT TREE 14-29 1/2" DBH W/CRZ SHOWN
	SLOPE 2-5%		PROPOSED SEC EARTH DIKE
	SLOPE 15-25% ON HIGHLY ERODIBLE SOILS		
	WETLAND		
	EXISTING FOREST		
	PROPOSED AFFORESTATION/REFORESTATION		
	PROPOSED BIORETENTION		
	EXISTING TREE CANOPY (NOT FOREST)		
	EXISTING SIGNIFICANT TREE 14-29 1/2" DBH W/CRZ SHOWN		
	SEC. 100' IMPACT		
	SEC. 100' IMPACT		
	SEC. 100' IMPACT		
	SEC. 100' IMPACT		
	SEC. 100' IMPACT		
	SEC. 100' IMPACT		
	SEC. 100' IMPACT		
	SEC. 100' IMPACT		
	SEC. 100' IMPACT		
	SEC. 100' IMPACT		

FOR LOCATION OF UTILITIES CALL 8-1-1 or 1-800-257-7777 OR LOG ON TO www.call811.com or http://www.misutility.net 48 HOURS IN ADVANCE OF ANY WORK IN THIS VICINITY  
 The excavator must notify all public utility companies with underground facilities in the area of proposed excavation and have those facilities located by the utility companies prior to commencing excavation. The excavator is responsible for compliance with requirements of Chapter 53A of the Montgomery County Code.

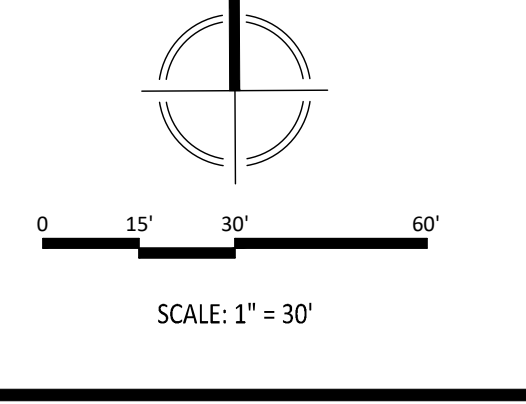

SEE SHEET FFCP-352 AREA 5

SEE SHEET FFCP-332 AREA 3

SEE SHEET FFCP-332 AREA 3

SEE SHEET FFCP-343 AREA 4

EX. 250' PEPCO RIGHT-OF-WAY

SEE SHEET FFCP-350 AREA 5

SEE SHEET FFCP-350 AREA 5

LAYOUT: FFCP-351 AREA 5, Plotted By: grimm