

VKA
 ENGINEERS PLANNERS
 LANDSCAPE ARCHITECTS SURVEYORS
 VIKI MARYLAND, LLC
 20251 CENTURY BOULEVARD, SUITE 400
 GERMANTOWN, MARYLAND 20874
 PHONE: (301) 916-4100
 FAX: (301) 916-2262
 GERMANTOWN, MD. MCLEAN, VA.

PREPARED FOR:
USL2 MR MONTGOMERY VILLAGE BUSINESS TRUST
 c/o MONUMENT REALTY
 750 17TH STREET, NW, SUITE 1100
 WASHINGTON, DC 20006
 202.777.2010
 RUSSELL HINES

DESIGN CONSULTANTS

ARCHITECTS
TORTI GALLAS AND PARTNERS, INC.
 1300 SPRING STREET, SUITE 400
 SILVER SPRING, MD 20910
 301.588.4800
 ERIK J. AULESTIA

ATTORNEY
LEITCH, EARLY & BREWER
 CHTD.
 3 BETHESDA METRO CENTER
 SUITE 460
 BETHESDA, MD 20814
 301.841.3832
 PATRICIA HARRIS

TRAFFIC ENGINEER
WELLS + ASSOCIATES
 8730 GEORGIA AVENUE, SUITE 200
 SILVER SPRING, MD 20910
 301.448.1333
 KEVIN BERGER

LANDSCAPE ARCHITECT
VKA MARYLAND, LLC
 20251 CENTURY BOULEVARD
 SUITE 400
 GERMANTOWN MD, 20874
 301.916.4100
 JOSH SLOAN

CIVIL ENGINEER
VKA MARYLAND, LLC
 20251 CENTURY BOULEVARD
 SUITE 400
 GERMANTOWN MD, 20874
 301.916.4100
 MIKE GOODMAN

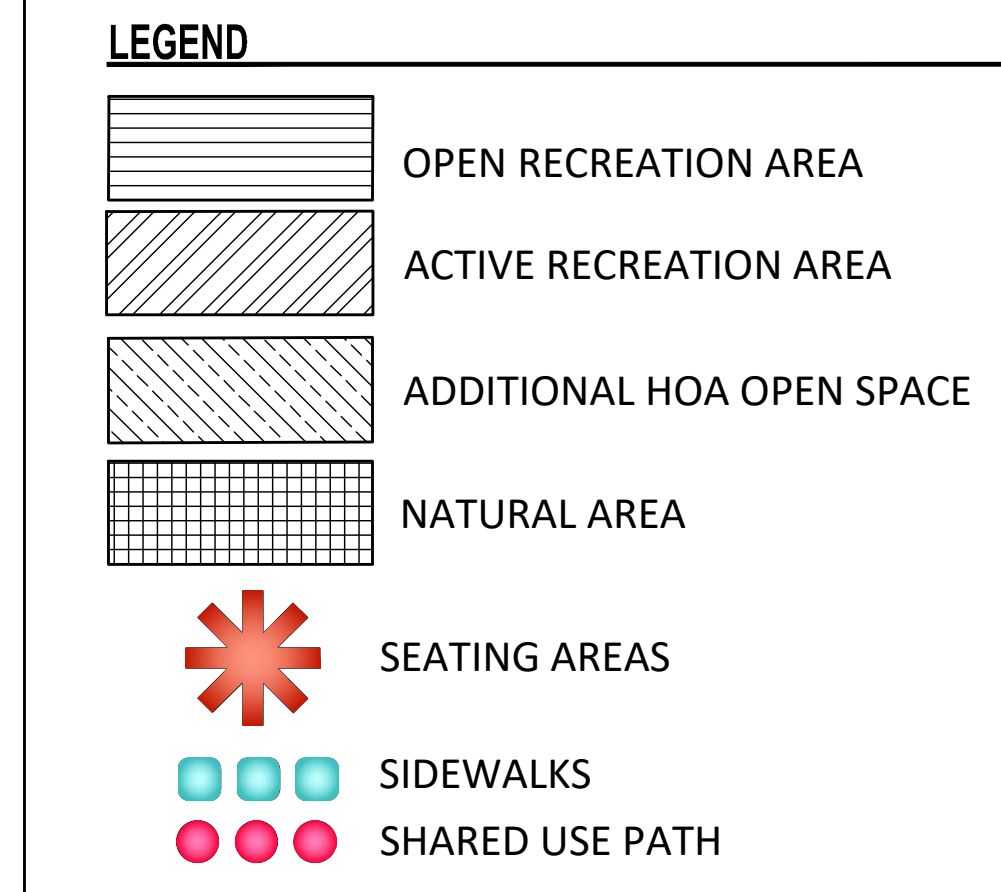

RECREATION DEMAND TABULATION

AREA 1 Proposed Residential Project - Units by Type and their Demand Points

Code	Housing Type	Quantity	Totals	Children	Teens	Young Adults	Adults	Seniors
1	Single-Family, 1.5 Units or more	0	0	0	0	0	0	0
2	Single-Family, 2 Units or more	11	11.54	24.76	17.04	16.83	13.53	14.13
3	Multi-Family (Apt/Condo/ Townhome)	0	0	0	0	0	0	0
4	Mobile Home	0	0	0	0	0	0	0
5	Other	0	0	0	0	0	0	0
Total Demand Points		11	11.54	24.76	17.04	16.83	13.53	14.13

Existing Offsite Park Facilities and their Supply Points

Park Facility	Quantity	Totals	Children	Teens	Young Adults	Adults	Seniors
Local Offsite Supply Point	0	0	0	0	0	0	0
State of Maryland Supply Point	0	0	0	0	0	0	0
Total Offsite Supply Points	0	0	0	0	0	0	0

Proposed Onsite Recreation Facilities and their Supply Points

Recreation Facility	Quantity	To Beas Points	Children	Teens	Young Adults	Adults	Seniors
Playground - Tot System	1	0%	11.54	4.80	2.66	2.82	1.12
Playground - Swing	1	0%	11.54	2.24	2.68	2.92	1.12
Playground - Toddler	1	0%	0	0	0	0	0
Playground - Teen	1	0%	0	0	0	0	0
Playground - Multi-Use	1	0%	0	0	0	0	0
Playground - Other	1	0%	0	0	0	0	0
Playground (Age 5-12) (Play Area)	1	0%	0	0	0	0	0
Total Onsite Supply Points	5	0%	11.54	7.04	2.66	2.82	1.12

Results: Demand, Supply & Adequacy

Age Group	Total Demand Points	Offsite Supply Points	Onsite Supply Points	Total Supply Points	Adequacy
Totals	11.54	0	11.54	11.54	Adequate
Children	24.76	0	11.54	11.54	Adequate
Teens	17.04	0	7.04	7.04	Adequate
Young Adults	16.83	0	2.66	2.66	Adequate
Adults	13.53	0	2.82	2.82	Adequate
Seniors	14.13	0	1.12	1.12	Adequate

OPEN SPACE AREA TABULATION

SITE AREA: 1,160,075 sf.

Category	Required (%)	Required (sf)	Provided (%)	Provided (sf)
COMMON OPEN SPACE				
REQUIRED:	10%	116,008 sf.	45%	527,647 sf.
PROVIDED:				
OPEN RECREATION AREA				
ILLUSTRATED:	3%	39,902 sf.		
ACTIVE RECREATION AREA				
ILLUSTRATED:	15%	170,757 sf.		
PARKLAND				
ILLUSTRATED:	27%	316,988 sf.		
ADDITIONAL HOA OPEN SPACE				
ILLUSTRATED:	36%	422,543 sf.		
ADDITIONAL NATURAL AREA				
ILLUSTRATED:	0%	0 sf.		
TOTAL OPEN SPACE				950,190 sf.

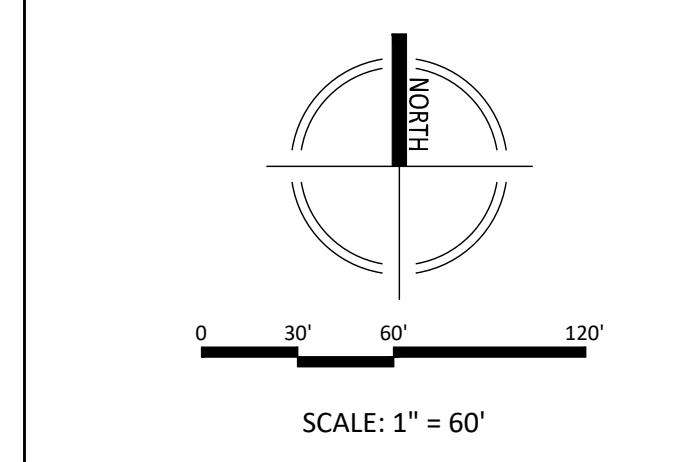

DEVELOPER'S CERTIFICATE

The undersigned agrees to execute all the features of the Site Plan Approval No. **SP# 820170130**, including Approval Conditions, Development Program, and Certified Site Plan.

Developer's Name: USL2 MR Montgomery Village Business Trust

Contact Person: Russell Hines

Address: 1200 K Street, NW, Suite 400, Washington, DC 20006

Phone: 202.777.2010

Signature: _____ Date: _____

REVISIONS

NO.	DATE	DESCRIPTION
1	08/09/17	DATE
2	08/31/17	DATE

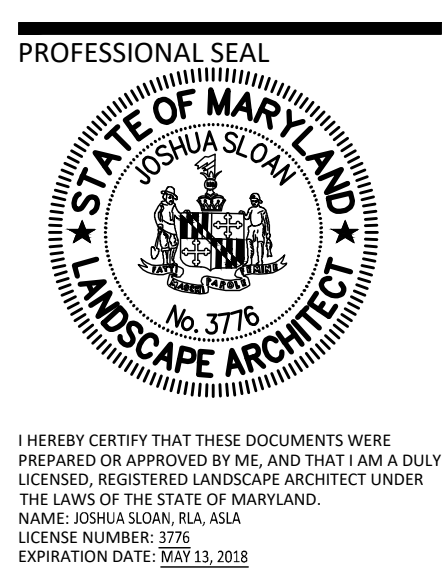

BLOOM MV AREA I-VI

9TH ELECTION DISTRICT
 MONTGOMERY COUNTY, MARYLAND
 WSSC GRID: 227NW09
 TAX MAP: FJ342

SP# 820170130

OPEN SPACE PLAN

AREA 1

DRAWN BY: _____
 DESIGNED BY: DLK-JS-SCM
 DATE ISSUED: May 5, 2017

VKA PROJECT: VM1920
 DRAWING NO.: _____
 SHEET NO.: OPEN-1

NOTE: SCHEMATIC DESIGN FOR ENTITLEMENT ONLY. NOT FOR CONSTRUCTION OR BIDDING PURPOSES.