



Vika
 ENGINEERS PLANNERS
 LANDSCAPE ARCHITECTS SURVEYORS
 VIKA MARYLAND, LLC
 20251 CENTURY BOULEVARD SUITE 400
 GERMANTOWN, MARYLAND 20874
 PHONE: (301) 916-4100
 FAX: (301) 916-2262
 GERMANTOWN, MD. MCLEAN, VA.

PREPARED FOR:
 USL2 MR
 MONTGOMERY VILLAGE
 BUSINESS TRUST
 c/o MONUMENT REALTY
 1700 S STREET, NW, SUITE 600
 WASHINGTON, DC 20006
 202.777.2010
 RUSSELL HINES

DESIGN CONSULTANTS

ARCHITECTS
 TORTI GALLAS AND
 PARTNERS, INC
 1300 SPRING STREET, SUITE 400
 SILVER SPRING, MD 20910
 301.588.4800
 ERIC J. AULESTIA

ATTORNEY
 LERCH, EARLY & BREWER
 CHTD.
 8 BETHESDA METRO CENTER
 SUITE 460
 BETHESDA, MD 20814
 301.841.3832
 PATRICIA HARRIS

TRAFFIC ENGINEER
 WELLS + ASSOCIATES
 8730 GEORGIA AVENUE, SUITE 200
 SILVER SPRING, MD 20910
 301.448.1333
 KEVIN BERGER

LANDSCAPE ARCHITECT
 VIKA MARYLAND, LLC
 20251 CENTURY BOULEVARD
 SUITE 400
 GERMANTOWN MD, 20874
 301.916.4100
 JOSH SLOAN

CIVIL ENGINEER
 VIKA MARYLAND, LLC
 20251 CENTURY BOULEVARD
 SUITE 400
 GERMANTOWN MD, 20874
 301.916.4100
 MIKE GOODMAN

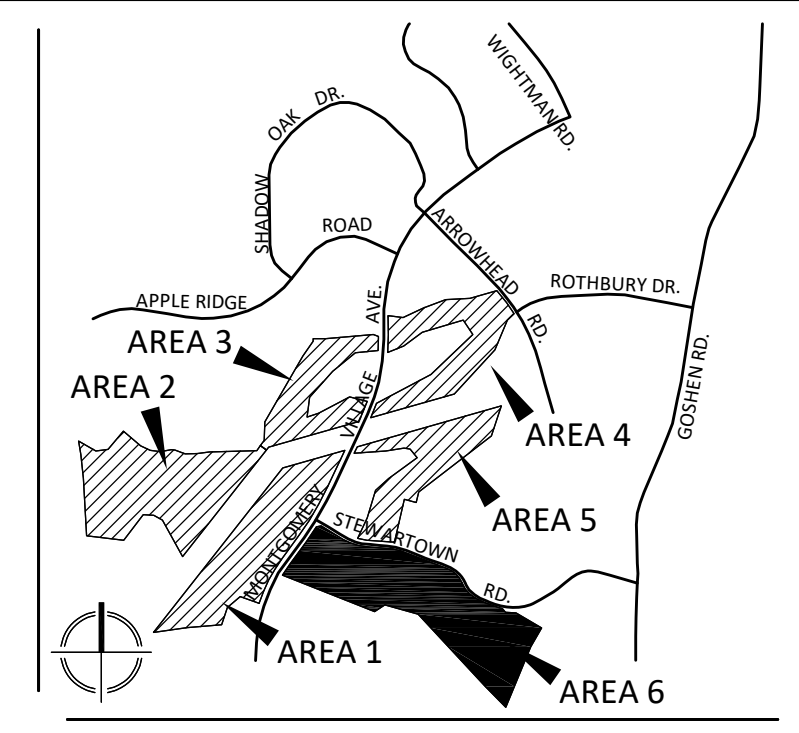

LEGEND

- STREET LIGHT
- STREET LIGHT PHOTOMETRIC AREA
- PEDESTRIAN LIGHT
- PEDESTRIAN LIGHT PHOTOMETRIC AREA

REVISIONS	DATE

PROFESSIONAL SEAL

**BLOOM MV
 AREA I-VI**

9TH ELECTION DISTRICT
 MONTGOMERY COUNTY,
 MARYLAND
 WSSC GRID: 227NW09
 TAX MAP: FU342

SP# 820170130

PHOTOMETRIC PLAN

AREA 6

DRAWN BY: DLK
 DESIGNED BY: DLK - JS - SCM
 DATE ISSUED: May 5, 2017

Vika PROJECT VM1920
 DRAWING NO.

SHEET NO. PM-205

DEVELOPER'S CERTIFICATE
 The undersigned agrees to execute all the features of the Site Plan Approval No. 820170130, including Approval Conditions, Development Program, and Certified Site Plan.
 Developer's Name: USL2 MR Montgomery Village Business Trust
 Contact Person: Russell Hines
 Address: 1200 K Street, NW, Suite 800, Washington, DC 20005
 Phone: 202.777.2000
 Signature: _____ Date: _____

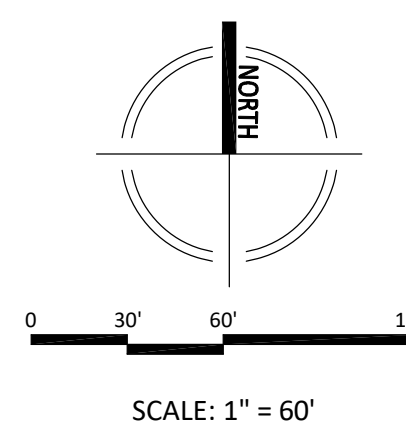

NOTE: SCHEMATIC DESIGN FOR ENTITLEMENT ONLY.
 NOT FOR CONSTRUCTION OR BIDDING PURPOSES.